

Wood dust Controlling the risks

HSE information sheet

Woodworking Sheet No 23 (Revision 2)

Introduction

This information sheet is one of a series produced by HSE's manufacturing sector on wood dust.^{1,2} It provides advice for woodworking employers. It explains what the health and safety risks from wood dust are and how they can be controlled. It will also help employers to ask the right questions when dealing with local exhaust ventilation (LEV) designers and suppliers.

Types of wood dust

In addition to the tiny particles of wood produced during processing, wood dust can also contain bacteria and fungal and moss spores. The quantity and type of wood dust will depend on the wood being cut and the machine you are using, for example:

- whether the timber is green or seasoned;
- whether it is a hardwood, softwood or composite board;
- how aggressive the machine cutter or blade profile is.

The biggest risk is from fine dust, as you can breathe this deep into your lungs where it will do the most damage. Fine dust will also spread further from the cutting process so it is important to clean ledges and other workroom surfaces regularly to prevent dust accumulating.

Why is it necessary to control wood dust?

Health risks

Wood dust is a **substance hazardous to health** because it can cause serious non-reversible health problems,² including:

- skin disorders;
- obstruction in the nose, and rhinitis;
- asthma;
- a rare type of nasal cancer.

Safety risks

Wood dust is flammable and, in certain situations, can cause a fire or explosion.³ Every year, premises are severely damaged or destroyed by wood dust fires that usually start in dust extraction equipment. Wood dust explosions in buildings are rare, except in the chipboard industry.

It also makes sense to control wood dust from a business point of view as you will need less time for clearing up, and there will be fewer slips and trips hazards caused by settled dust.

What causes high wood dust exposures?

The following activities are likely to produce high dust exposures, some over long periods:

- machining operations, particularly sawing, routing and turning;
- sanding, by machine and by hand;
- using compressed airlines to blow dust off furniture and other articles (to be avoided) before spraying;
- hand assembly of machined or sanded components;
- operations involving processing composite boards, eg medium-density fibreboard (MDF);
- the bagging of dust from dust extraction systems;
- housekeeping, especially if sweeping up and using compressed airlines (again to be avoided).

What the law says

Because of the potential health problems, wood dust is covered by the Control of Substances Hazardous to Health Regulations (COSHH).⁴ These set out the legal requirements to protect workers from health risks arising from hazardous substances at work. Under COSHH, employers (including contractors) have a duty to carry out a suitable and sufficient risk assessment and take steps to ensure they prevent or adequately control exposure.

COSHH states that, where it is not reasonably practicable to prevent exposure to a hazardous

substance, control of that exposure should only be treated as adequate if:

- **the principles of good practice for the control of exposure are applied.** This is set out in Schedule 2A to the COSHH Regulations and includes the requirement to provide suitable personal protective equipment, such as respiratory protective equipment (RPE), combined with your other control measures, such as LEV, if adequate control cannot be achieved;
- **any workplace exposure limit (WEL) is not exceeded.** The WEL for hardwood dust is $3\text{mg}/\text{m}^3$ (based on an 8-hour time-weighted average). The WEL for softwood dust is $5\text{mg}/\text{m}^3$ (based on an 8-hour time-weighted average). For mixtures of hardwood and softwood dusts the WEL for hardwood dust of $3\text{mg}/\text{m}^3$ applies to all wood dusts present in that mixture;
- **for a substance that has the potential to cause cancer or occupational asthma (such as wood dust) exposure is reduced to as low a level as is reasonably practicable (ALARP).** This means that, even if your control measures (eg LEV) reduce exposure to below the WEL, but there remain improvements that could further reduce the exposure, then you should make these improvements if reasonable and practicable.

In all cases, employers should consult their workers or their representatives when assessing risks and making decisions about control measures. Good communication and co-operation are essential if control measures are to be accepted and adopted by the workforce.

How do I control wood dust exposure?

The best way for you to do this is to use fixed LEV that will effectively control the dust at source as it is produced. In some cases, the hood(s) used to capture the dust can be part of the machine housing or guards, such as the crown guard shown in Figure 1.

Fine wood dust becomes suspended in air and capturing the dust is all about controlling the movement of this dusty air. This can be difficult as the high-speed rotating blades and cutters of woodworking machines act like fans and generate strong air movements.

The job of the LEV system is to contain this air movement and with it the dust. Many LEV designs fail to do this because the hood design is wrong (for more information, see chapter 6 of HSG258⁵). Hoods should be designed to contain, receive and control these air movements and there are some simple rules-of-thumb that you can use to create the most effective

and efficient LEV hoods. An example of one simple improvement – to improve the volume flow rate (VFR) – is to increase the diameter of the extract point from the crown guard hood of a circular saw by adding a spigot, as detailed in Figure 1. This improvement to the VFR will remove the dusty air in the hood more efficiently so there will be less chance of ‘leakage’ of dusty air into the workroom.

You might need to use RPE as a temporary measure to control exposure where engineering controls are being developed or modified. You may also need RPE for additional protection for short-term jobs such as cleaning and maintenance that produce high levels of dust.

When cleaning up, use vacuum equipment that meets at least the dust class M (medium hazard) classification. Do not use compressed airlines or hand brushing, particularly on clothing, as these will just create dust clouds and redistribute the dust.

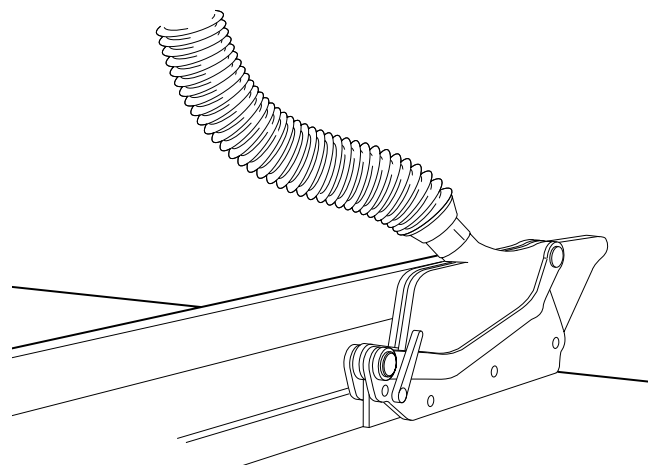

Figure 1 Improving volume flow rate on crown guards

LEV design and management

In addition to capturing the fine wood dust, the design of the LEV system should also allow it to take away the larger/heavier chips and shavings. LEV systems may look simple but there’s a lot more to them than a fan and some ductwork. To get the best from your LEV you must understand:

- the particular requirements of LEV systems used in woodworking;
- the basic design principles;
- how to check that your LEV is working properly.

The woodworking industry is unusual in that often the LEV extracts from different combinations of machines at different times. As the airflows through the hoods are not fixed, the LEV system cannot be ‘balanced’.

Balancing means getting the airflow needed to control the wood-dust cloud at every hood in the system after first installation. This is achieved by determining the various airflows in each branch, hood resistance etc.⁵ Having one fan and filter system that supplies suction to a number of machines means that:

- the system should be designed to run the maximum number of machines that will be used at any one time. You therefore need to know the **maximum number of hoods that the fan can extract from and still control the dust**. Displaying a plan in the workplace that shows which combinations of hoods can be open will help to manage the use of the system so this number is not exceeded;
- dampers need to be opened and closed to make sure that there is the correct VFR at the machines being used. This can be done automatically but in most cases relies on the operator doing it manually. The simplest way to check that the dampers are in the correct position, and that there is the correct airflow, is to fit airflow indicators to the hoods. They may be fitted to each hood or to the branch duct supplying a group of hoods, as long as potential hood or hood-duct blockages will be easily seen. (See 'Simple ways to check your LEV controls are working'.)

It is important that you also read INDG408 *Clearing the air: A simple guide to buying and using local exhaust ventilation (LEV)*,⁶ as this covers:

- how to specify and buy LEV and have it tested or 'commissioned' after installation – making sure it actually works and effectively controls the wood dust;
- how to check and maintain it, including the legally required thorough examination and test by a 'competent person' – making sure it stays working. Most LEV systems need a thorough examination and test once each year (legally you are allowed 14 months between tests) to make sure it works well and continues to protect your employees;
- training requirements for operators, supervisors and managers – making sure they know how it works and how to check it's working.

A poorly designed or maintained LEV system will not protect your employees' health; running it will just be a waste of electricity. A well-designed and maintained system will control the dust **and** be cheaper to run.

General LEV requirements

The LEV system should be simple and robust in design so that it requires minimum maintenance. However, it must also be effective and you can check this easily with either a dust lamp or a smoke generator (see 'Simple ways to check your LEV controls are working').

Maintenance should be simple to carry out, with clear 'how to' instructions. Ducts should have inspection doors so you can check for and clear blockages.

The LEV system should be designed to supply the correct VFRs. These will vary for each type of woodworking machine, but it is important that they are high enough to keep the dusty air within the hood and then convey the dust and chippings away through the ductwork to the filter. Advice should also be sought from the machine manufacturer to find out what VFR they recommend be made available at the machine's connection to the LEV system.

The LEV ductwork should be of a large enough diameter to enable the correct VFR to be maintained, but not so large as to reduce the air transport velocity to below that needed to transport the wood dust and chippings.

The 'air transport velocity' is the minimum value necessary to keep dust and chippings airborne in ductwork etc. BS EN 12779:2004⁷ specifies that an air transport velocity of between 20–25 m per second is required but this can be a lower value for fine dry wood dust. It is therefore important to get advice from a competent LEV engineer.

The LEV system will work correctly only if a minimum number of hoods or inlets are open – to allow in sufficient airflow. You should know what this number is, and train your employees to make sure that **at least** this number are always open when the system is in use. If transport velocity is not maintained, dust and chippings will settle out in the ductwork, choking off airflow and reducing LEV control effectiveness.

Make sure that you have trained a 'responsible person' to manage your LEV controls to maintain system performance. They will need an appropriate user manual that covers the whole LEV system. Get one from your supplier, or develop one yourself (you may need some help to do this).

Hood design

The LEV hood design is key to successfully controlling wood dust. The two main reasons why LEV systems fail to control dust emissions and exposure are:

- poor hood design;
- a VFR that is too low.

In theory, the machine's 'extract port' only needs to be connected to your LEV system and the manufacturer's recommended VFR rate applied. However, the LEV commissioning will need to confirm that the hood design and VFR rate are effective and control is being achieved.

As mentioned earlier, you can also check yourself that control is being achieved by using either a dust lamp or smoke generator (see 'Simple ways to check your LEV controls are working'). You should spend some time making sure that the hood design is right, as this will give you better control and save you money. Consider the following points:

- The LEV hoods should be designed to enclose and receive the air movement created by the moving parts of the machine that produces the wood dust. This will increase control effectiveness and minimise the VFR of air needed for control. You should try and get the hoods as close as possible to the source and positioned so that they receive the dust-laden airstream. The greater the degree of enclosure of the source, the better the control will be. As this will require a lower VFR there will be a reduced running cost.
- Make sure that the hood airflow either contains or controls the air movement created by the woodworking process. Match the hood volume airflow to the airflow created by the woodworking process – getting the right hood and the right extraction airflow are key to effective control.
- Where the process to be controlled is outside of the LEV hood, and the hood airflow has to 'reach out' and 'capture' the dusty air, don't be over-optimistic about the 'reach' of such hoods.
- Take care that a badly designed hood and duct connection does not cause it to become blocked with wood splinters and shavings.

Most machines will need more than one LEV hood. A vertical spindle moulder, for example, should have extraction behind the cutter guard and an additional hood to capture dust at the out-feed side of the cutters. Some simple and cheap ways to improve hood design and their effectiveness can be found in HSE's woodwork control guidance sheets.⁸

Duct design

Airflow through the ductwork should be as smooth as possible. Avoid tight bends and take care at duct junctions – see Figure 2.

A smooth airflow wastes less energy and creates less noise. Avoid excessive duct lengths and numerous bends, as these will reduce the efficiency of the system. You should only modify the original extraction system (new extensions etc) if the effect on the system has been properly assessed by a competent person. The LEV system will usually need to be recommissioned to prove that control of the wood dust is still being achieved. This will also give you the new set of performance parameters to use at the 'thorough examination and test'.

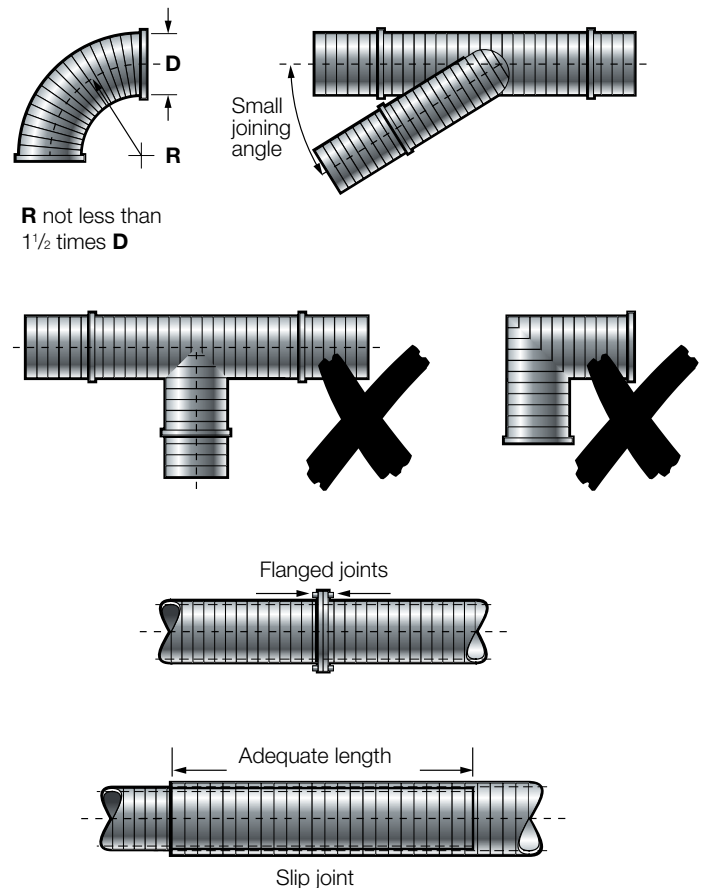

Figure 2 Good and bad examples of bends, junctions and joints in ducting

BS EN 12779 advises that lengths of flexible ducting should ideally only be longer than 0.5 m if it is essential to accommodate the movement of the woodworking machine. Keep the use of flexible ducting to a minimum because:

- it can be easily damaged and blocked;
- it increases the resistance to airflow, so reduces the LEV system's efficiency and increases running costs;
- flexible ducting costs more than rigid sheet metal ducting.

BS EN 12779 also advises that flexible ducting should be earthed to avoid the risk of a static build-up. This can be achieved by making a connection from the flexible ducting's metal helix to the adjacent rigid metal ducting.

Fans and air cleaners

The fan must be capable of providing the total airflow required for the maximum number of machines that you plan to use at any one time. As mentioned earlier, the woodworking industry is unusual in that the LEV extracts from different combinations of machines at different times, so the balance of the LEV system cannot be fixed.

Other factors to consider when selecting a fan are the overall resistance of the system (caused by bends, junctions etc), expected noise levels and limitations of space. To reduce their impact on workplace noise, where possible, have fans and air movers outside the workroom. This will also keep the ductwork within the workroom under negative pressure and any leakage inwards.

Where large volumes of wood waste are extracted, consider a settlement vessel or a cyclone before the air is presented to the air filters. This will reduce the load on the filters and extend the life of the filter bags. Consider recycling and reuse of wood waste. There are usually opportunities to improve performance and save money, ie you can use it to heat the workshop or sell it to recycling companies.

Wood dust from most machining processes will burn and can explode. Air cleaners should be designed and located with this in mind and, where possible, they should be situated in the open air, away from thoroughfares or other work areas. Where necessary, units should be enclosed and fitted with adequate explosion relief, which will vent to a safe place in the event of an explosion.³ The installation of a fire (spark) detection system may prove to be cost-effective for certain installations.

Simple ways to check your LEV controls are working

Dust lamps

Used correctly, a dust lamp is a cheap, powerful tool to help you identify where dust problems such as leaks are and whether an extraction system is working effectively. Airborne wood dust is normally invisible to the naked eye but Figure 3 shows how effective a dust lamp is in identifying a dust problem.

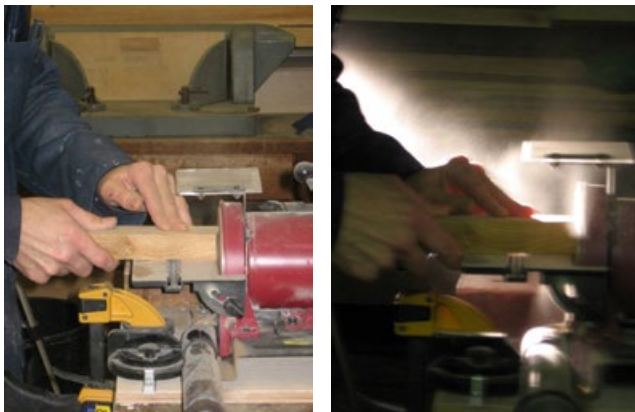

Figure 3 Effectiveness of a dust lamp in showing the dust cloud produced by sanding. This is normally invisible to the naked eye

The dust lamp should be set up to observe forward-scattering of light, as shown in Figure 4. Mount it on a tripod or other stand and point the lamp to shine through the area where you think the dust cloud is. If possible, lower the background lighting by turning off workshop lights. Lock the lamp into the 'on' position, walk around the process and look back up the beam at a slight angle, through the airborne dust. Protect your eyes from the main beam using a shield, such as a book or piece of board etc, and record your observations with a camera or even better a video.

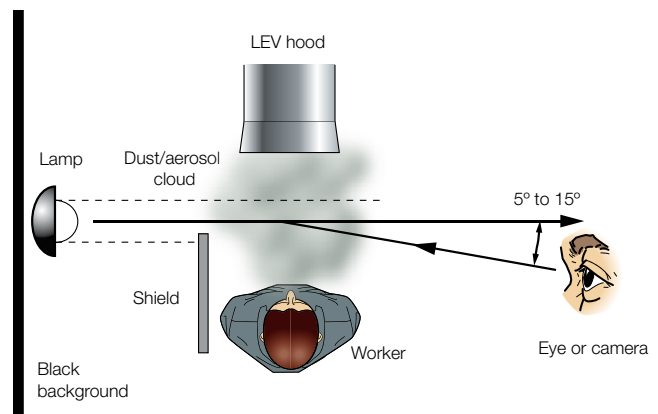

Figure 4 The principle of using a dust lamp to observe a particle cloud

Smoke generators

Smoke generators produce variable amounts of smoke for prolonged periods. This will allow you to make air movements visible so you can:

- simulate the size, velocity and behaviour of wood dust clouds;
- confirm containment within a hood;
- identify draughts and air currents.

Always carry out a smoke test with the process running. You may also need to take care as the smoke can set off smoke detectors.

Checking and maintenance

Your LEV system is a health-critical control in the same way that your machinery guarding is safety-critical. The law requires that LEV must be maintained (COSHH regulation 9). To make sure it continues to work properly follow the instructions in your user manual. These should include:

- regular checks of hoods and ductwork for damage or blockages;
- checking the condition of the filter and cleaning it when required.

Maintenance issues are covered in greater detail in INDG408 *Clearing the air: A simple guide to buying and using local exhaust ventilation (LEV)*.

Checking airflow

There should be procedures in place to check the correct VFR is entering the hood(s). For example, checking to make sure it has not been reduced by a closed damper that someone has forgotten to open, or by a blockage. HSE guidance⁵ suggests fitting airflow indicators because they give you a clear and continuous indication that the VFR is adequate and that the hood is working properly; see Figure 5. This is critical for unbalanced LEV systems such as used in woodworking, where the operator has to regularly adjust dampers when machines come in and out of use. Other options for checking air velocity are by using an airflow meter, or visually checking effectiveness using a dust lamp or smoke generator. However, these methods will both take longer and, in the long run, be more expensive and time-consuming.

Some suppliers of LEV systems now provide airflow indicators with new installations, or can fit them to existing systems. Set-up and calibration is best done when the LEV controls are first commissioned⁶ after installation. If fitting them to existing systems, then you will require a recommissioning test.

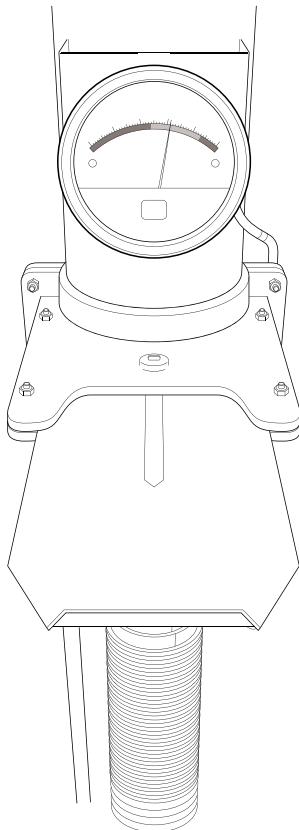

Figure 5 Airflow indicator

References

- 1 *Selection of respiratory protective equipment suitable for use with wood dust* Woodworking Information Sheet WIS14(rev1) HSE 2012 www.hse.gov.uk/pubns/wis14.htm
- 2 *Safe collection of wood waste: Prevention of fire and explosion* Woodworking Information Sheet WIS32(rev1) HSE 2011 www.hse.gov.uk/pubns/wis32.htm
- 3 *Control of substances hazardous to health (Fifth edition). The Control of Substances Hazardous to Health Regulations 2002 (as amended)*. Approved Code of Practice and guidance L5 (Fifth edition) HSE Books 2005 ISBN 978 0 7176 2981 7 www.hse.gov.uk/pubns/books/l5.htm
- 4 *Controlling airborne contaminants at work: A guide to local exhaust ventilation (LEV)* HSG258 (Second edition) HSE Books 2011 ISBN 978 0 7176 6415 3 www.hse.gov.uk/pubns/books/HSG258.htm
- 5 *Clearing the air: A simple guide to buying and using local exhaust ventilation (LEV)* Leaflet INDG408 HSE Books 2008 (priced packs ISBN 978 0 7176 6300 2) www.hse.gov.uk/pubns/indg408.pdf
- 6 *BS EN 12779:2004 Safety of woodworking machines. Chip and dust extraction systems with fixed installation. Safety-related performances and safety requirements* British Standards Institution
- 7 HSE's woodwork control guidance sheets can be found on the COSHH website www.hse.gov.uk/coshh/industry/woodworking.htm

Further information

Wood dust and LEV:
www.hse.gov.uk/woodworking/index.htm

Airflow indicators and LEV systems:
www.hse.gov.uk/lev/index.htm

COSHH: www.hse.gov.uk/coshh/index.htm

Asthma: www.hse.gov.uk/asthma/index.htm

For information about health and safety, or to report inconsistencies or inaccuracies in this guidance, visit www.hse.gov.uk/. You can view HSE guidance online and order priced publications from the website. HSE priced publications are also available from bookshops.

British Standards can be obtained in PDF or hard copy formats from BSI: <http://shop.bsigroup.com> or by contacting BSI Customer Services for hard copies only Tel: 020 8996 9001
email: cservices@bsigroup.com.

This leaflet contains notes on good practice which are not compulsory but which you may find helpful in considering what you need to do.

This leaflet is available at
www.hse.gov.uk/pubns/wis23.htm.

© *Crown copyright* If you wish to reuse this information visit www.hse.gov.uk/copyright.htm for details. First published 11/12. Revised 03/20.